

NOZZLE CHART	
NOZZLE ID	NPT SIZE
N1	1/4
N2	1
N3	3
N4	6
N5	MANWAY

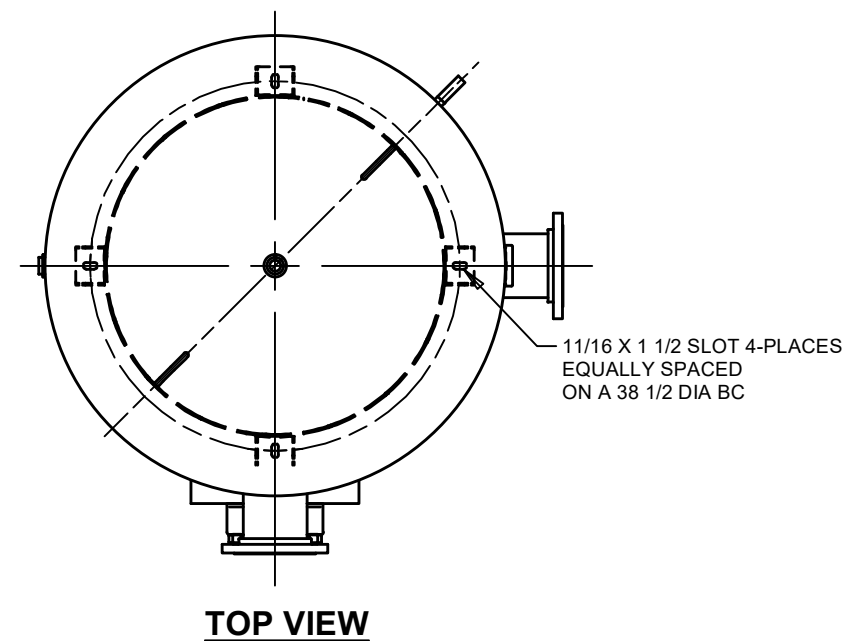
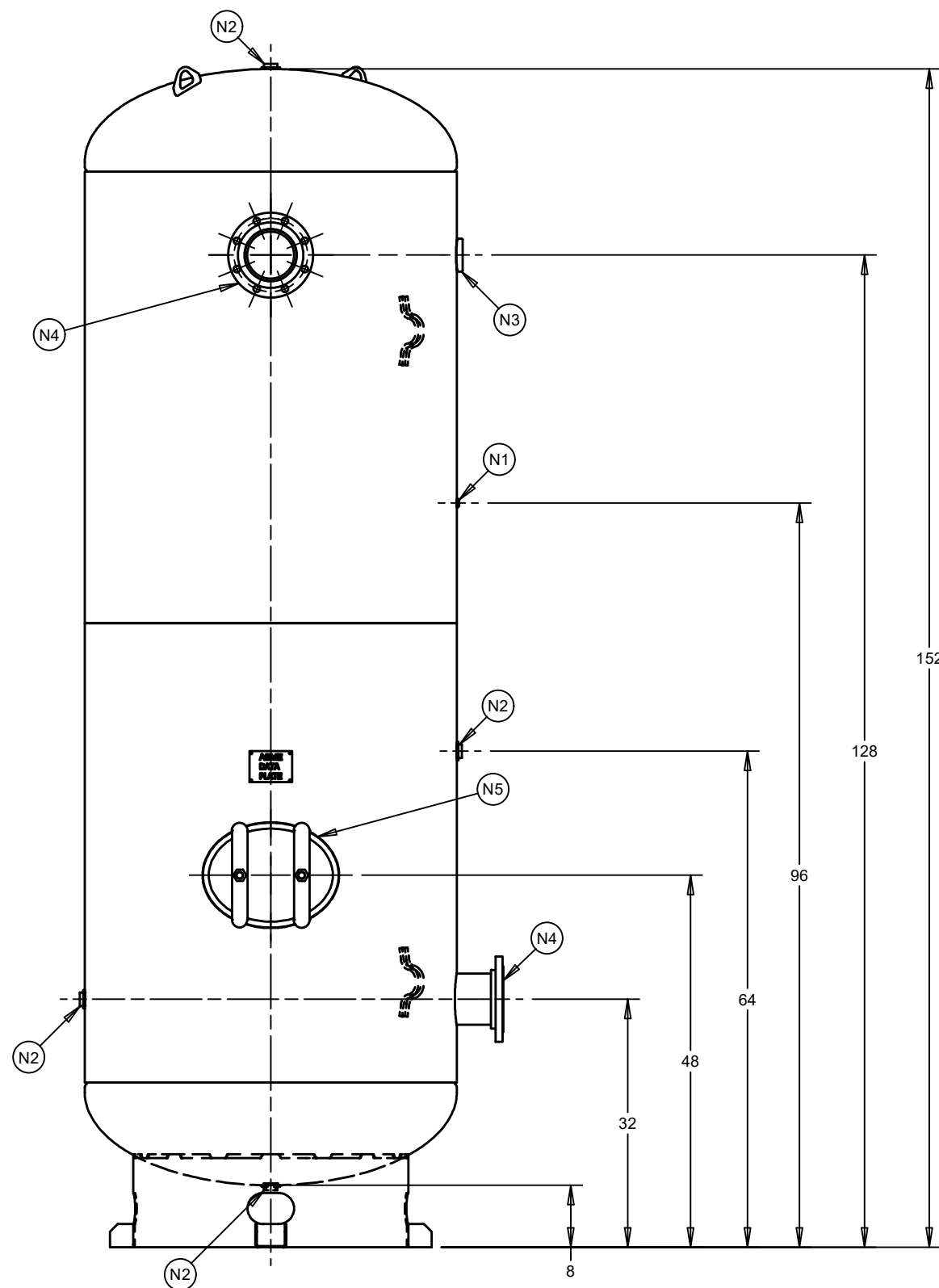

DESIGN INFORMATION	
SPECIFICATION	VALUE
DIAMETER O.D./I.D.	48 O.D.
MAWP	155 PSI AT 400°F
MDMT	-20°F AT 155 PSI
CAPACITY	APPROX 1060 GALLONS
SHIPPING WEIGHT	1950 LBS
CRN	L4208.5C

(BUILT IN ACCORDANCE WITH LATEST EDITION OF SECTION VIII DIV 1 ASME CODE)

THIS DRAWING & SPECIFICATIONS ARE PROPERTY OF SPVG AND MAY NOT BE COPIED, REPRODUCED, OR USED IN WHOLE OR PART, AS A BASIS FOR DESIGN MANUFACTURE OR SALE WITHOUT PRIOR PERMISSION FROM SPVG.

REV	DESCRIPTION	BY	DATE
F34	ISSUED		

TITLE VERTICAL AIR RECEIVER					
CUSTOMER STOCK		DRAWN KAT 9/17/2016	CHECKED DMM 10/7/2016	DRAWING NO <b>A10132</b>	REV <b>F34</b>
TYPE ASME		SIZE: B SHEET 1 OF 1			