

NOZZLE CHART	
NOZZLE ID	NPT SIZE
N1	1/2
N2	1
N3	1 1/2
N4	2
N5	4
N6	MANWAY

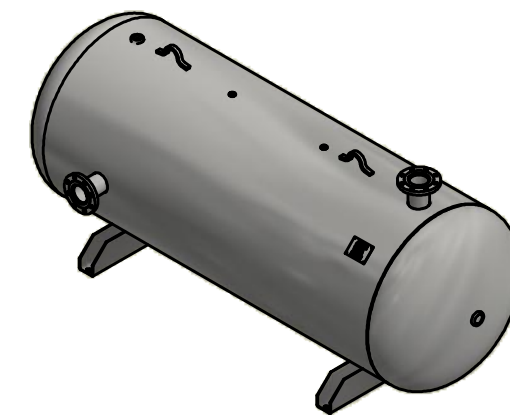
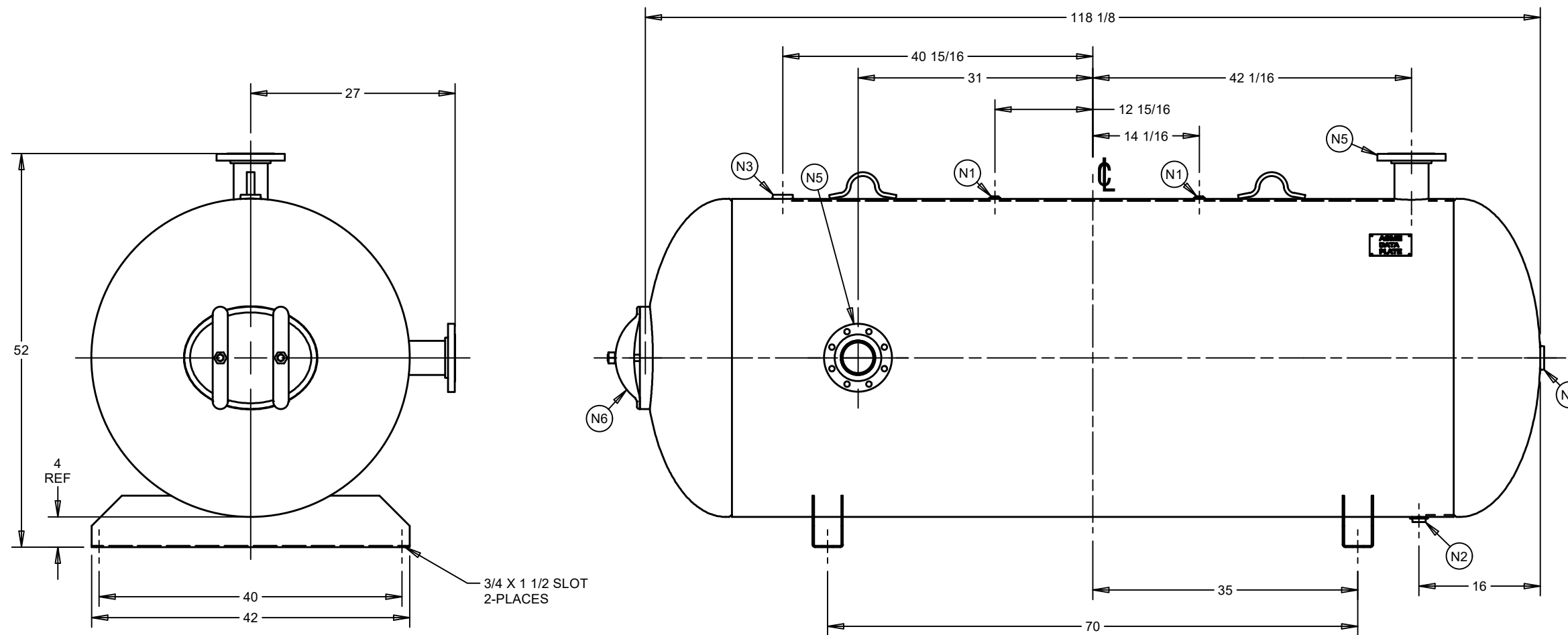

DESIGN INFORMATION	
SPECIFICATION	VALUE
DIAMETER O.D./I.D.	42 O.D.
MAWP	150 PSI AT 400°F
MDMT	-20°F AT 150 PSI
CAPACITY	APPROX 660 GALLONS
SHIPPING WEIGHT	1400 LBS
CRN	H9097.5C

TITLE HORIZONTAL AIR RECEIVER		DRAWN KAT		CHECKED DMM		DRAWING NO A10358		REV C13	
CUSTOMER STOCK		DATE 10/6/2016		DATE 10/17/2016		SIZE: B		SHEET 1 OF 1	
TYPE ASME									

(BUILT IN ACCORDANCE WITH LATEST EDITION OF SECTION VIII DIV 1 ASME CODE)

THIS DRAWING & SPECIFICATIONS ARE PROPERTY OF SPVG AND MAY NOT BE COPIED, REPRODUCED, OR USED IN WHOLE OR PART, AS A BASIS FOR DESIGN MANUFACTURE OR SALE WITHOUT PRIOR PERMISSION FROM SPVG.

REV	DESCRIPTION	BY	DATE
C13	ISSUED		