

NOZZLE CHART	
NOZZLE ID	NPT SIZE
N1	1/2
N2	1
N3	2
N4	3
N5	6
N6	MANWAY

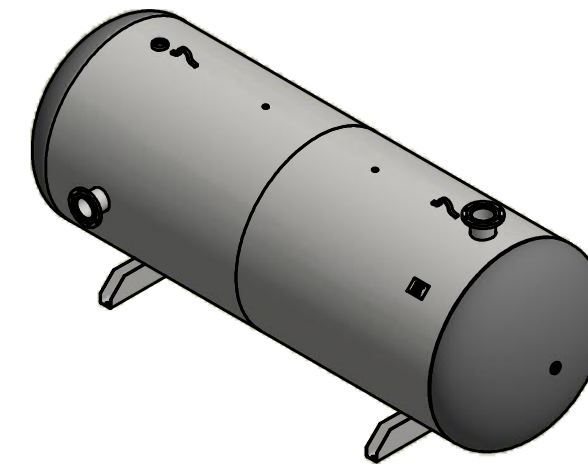
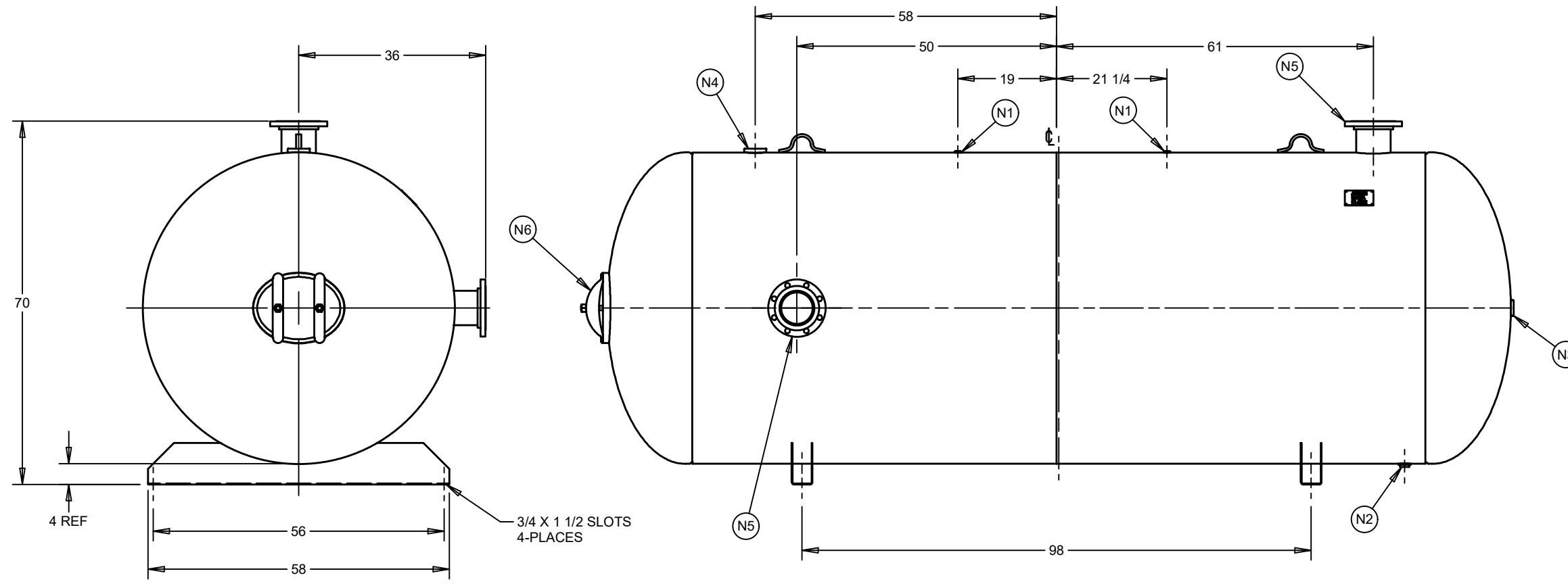

DESIGN INFORMATION	
SPECIFICATION	VALUE
DIAMETER O.D./I.D.	60 O.D.
MAWP	150 PSI AT 400°F
MDMT	-20°F AT 150 PSI
CAPACITY	APPROX 2000 GALLONS
SHIPPING WEIGHT	3516 LBS
CRN	L6794.56801234T9YN

TITLE HORIZONTAL AIR RECEIVER		DRAWN KAT		CHECKED DMM		DRAWING NO A10665		REV D12	
CUSTOMER STOCK		TYPE ASME		DATE 9/30/2016 10/17/2016		SIZE: B		SHEET 1 OF 1	

REV	DESCRIPTION	BY	DATE
D12	ISSUED		

(BUILT IN ACCORDANCE WITH LATEST EDITION OF SECTION VIII DIV 1 ASME CODE)
THIS DRAWING & SPECIFICATIONS ARE PROPERTY OF SPVG AND MAY NOT BE COPIED, REPRODUCED, OR USED IN WHOLE OR PART, AS A BASIS FOR DESIGN MANUFACTURE OR SALE WITHOUT PRIOR PERMISSION FROM SPVG.