

NOZZLE CHART	
NOZZLE ID	NPT SIZE
N1	1/4
N2	1
N3	3
N4	4
N5	MANWAY

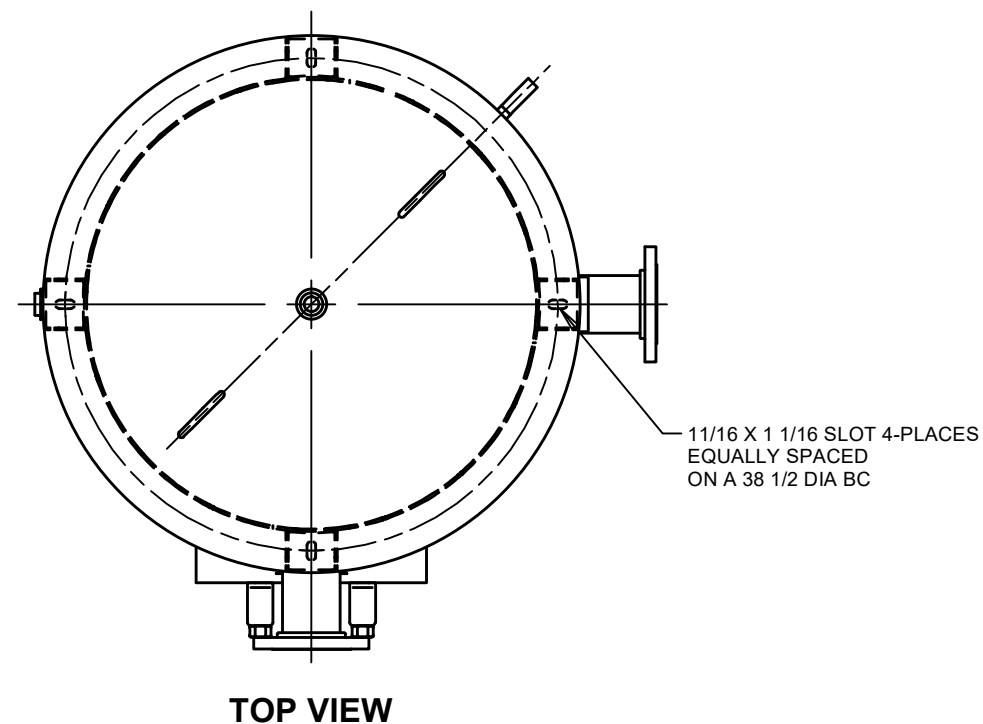
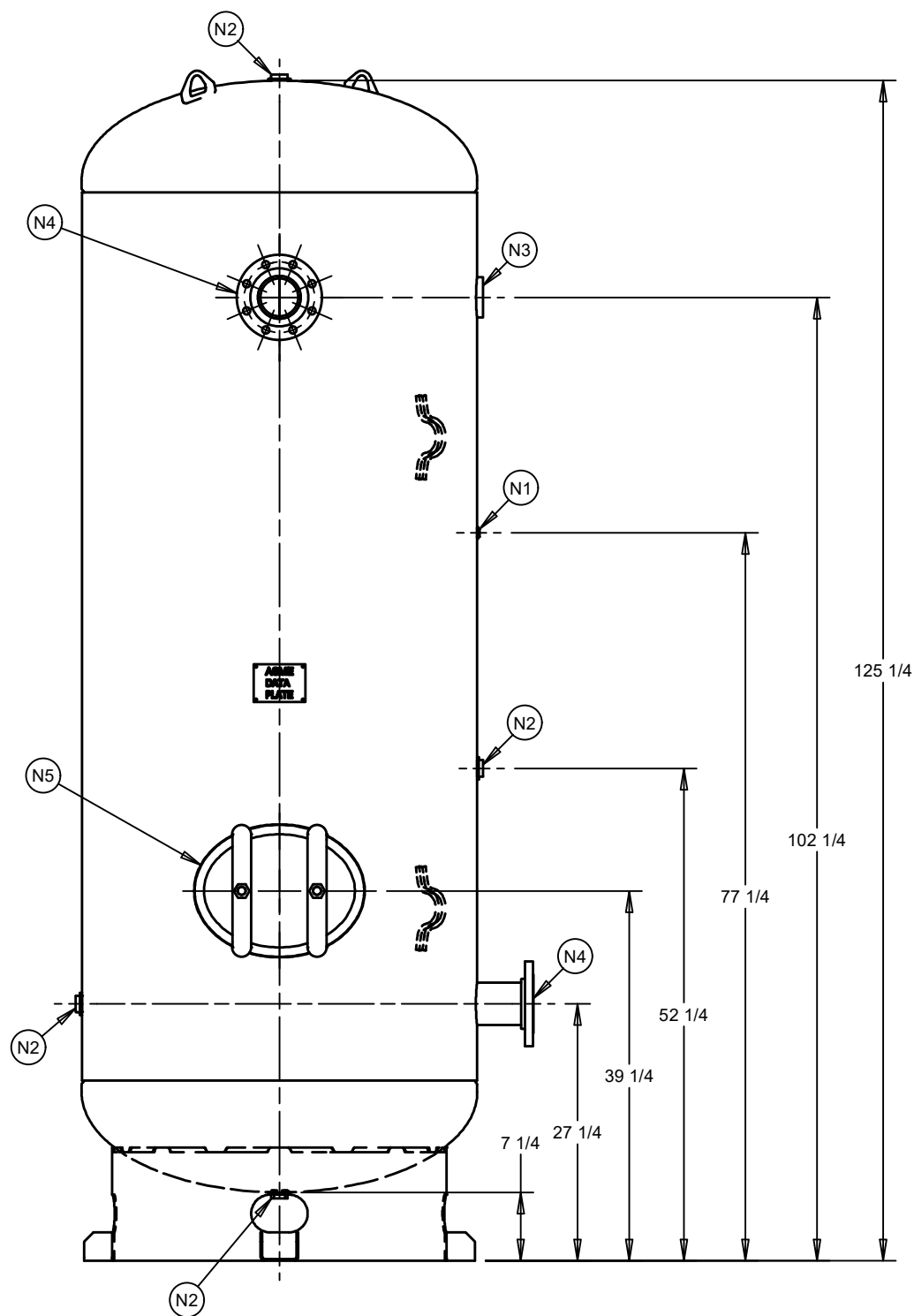

DESIGN INFORMATION	
SPECIFICATION	VALUE
DIAMETER O.D./I.D.	42 O.D.
MAWP	200 PSI AT 400°F
MDMT	-20°F AT 200 PSI
CAPACITY	APPROX 660 GALLONS
SHIPPING WEIGHT	1461 LBS
CRN	M1699.5621430

(BUILT IN ACCORDANCE WITH LATEST EDITION OF SECTION VIII DIV 1 ASME CODE)

THIS DRAWING & SPECIFICATIONS ARE PROPERTY OF SPVG AND MAY NOT BE COPIED, REPRODUCED, OR USED IN WHOLE OR PART, AS A BASIS FOR DESIGN MANUFACTURE OR SALE WITHOUT PRIOR PERMISSION FROM SPVG.

REV	DESCRIPTION	BY	DATE
F16	ISSUED		

TITLE VERTICAL AIR RECEIVER					
CUSTOMER STOCK		DRAWN KAT 9/13/2016	CHECKED DMM 10/7/2016	DRAWING NO <b>C100950-XF16</b>	REV
TYPE ASME		SIZE: B		SHEET 1 OF 1	