

CODE/ADDENDA _____ APPROVED _____
 RELEASED FOR PRODUCTION
 O.C. _____ DATE _____

NO.	QTY	SUB.DWG.	DESCRIPTION	SA106-B
M1	1	A73363	HINGED CLOSURE: 12.75 OD X .500	
N1	1	A20910	NAMEPLATE: ASME / NB	AP.G

NO.	QTY	SUB.DWG.	DESCRIPTION	SA106-C
H1	2			
S1	1			
F1	2	AS0206	RFSO ASSY: 6" 150# SCH 40 X 7"	SA106-C
F2	1		FLANGE: 2" NPT FLT	SA-181-70
F3	3		FLANGE: 1/2" NPT	SA-181-70
P1	2		COVER: 6" 150# RFSO PLASTIC	
P2	1		PLUG: 2" NPT HX HD (O-RING STYLE)	
P3	3		PLUG: 1/2" PLASTIC	
R1	1		O-RING FOR 2" FLANGE	
A1	1	AB5004	BASERING ASSY: FOR 36" TANK	AP.G
A2	2	AB4600	LIFT LUG: 1/2 X 3 X 5 D-SHAPED	AP.G
A3	1	A78474	BAFFLE: .224 X 24 X 24	AP.G

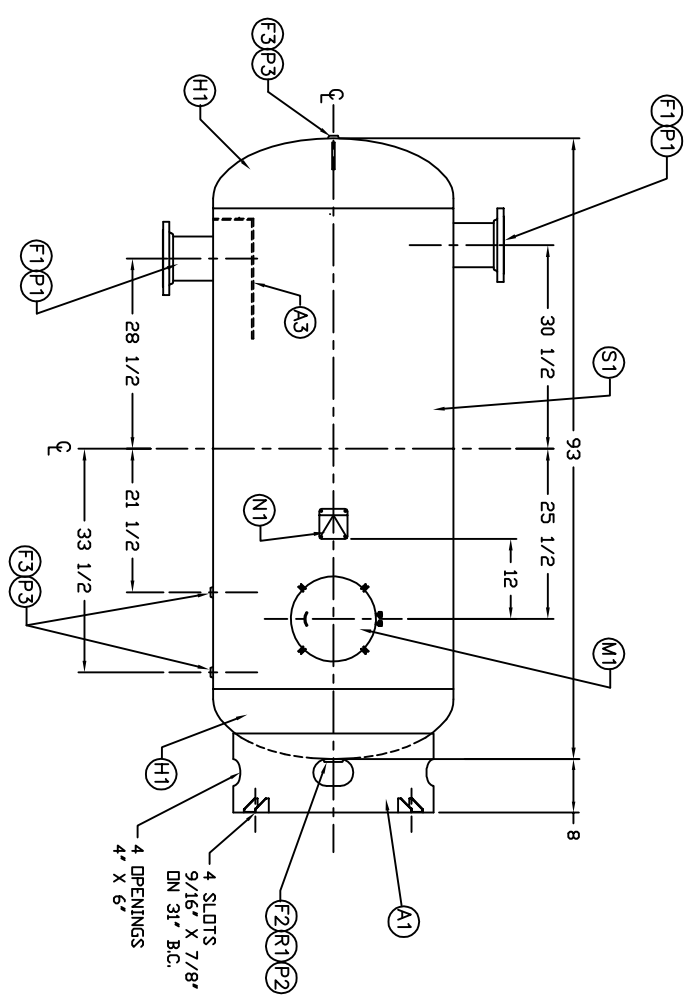
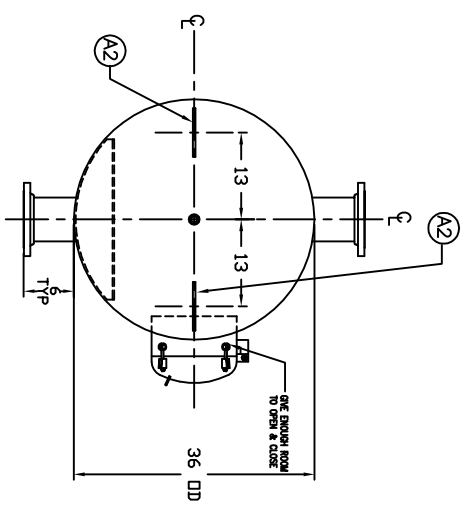

SYMBOL	DATE	BY	REVISION	APP
			1 FULL VACUUM AT 566°F	

NOTES

SPECIFICATIONS

0.0, 36 LGTH, 93
 MAMP 150 PSI @ 566 F
 CRN ---
 WELD DETAILS: M-1932
 STD. TOLERANCES (UNLESS OTHERWISE NOTED): M-2461

MANCHESTER TANK

VERTICAL VACUUM RECEIVER

DRAWN BY	DATE	SCALE: NONE
APP. BY	DATE	DRAWING NO. 300960