

THIS DRAWING & SPECIFICATIONS ARE PROPERTY OF MORGANTON PRESSURE VESSELS AND MAY NOT BE COPIED, REPRODUCED, OR USED IN WHOLE OR PART, AS A BASIS FOR DESIGN MANUFACTURE OR SALE WITHOUT PRIOR PERMISSION FROM MORGANTON PRESSURE VESSELS.

DESIGN INFORMATION	
SPECIFICATION	VALUE
DIAMETER (O.D.)	30.000"
MAWP	300 PSI AT 500°F
MDMT	-20°F AT 300 PSI
CAPACITY	APPROX 240 GALLONS
APPROX. WEIGHT	667 LBS

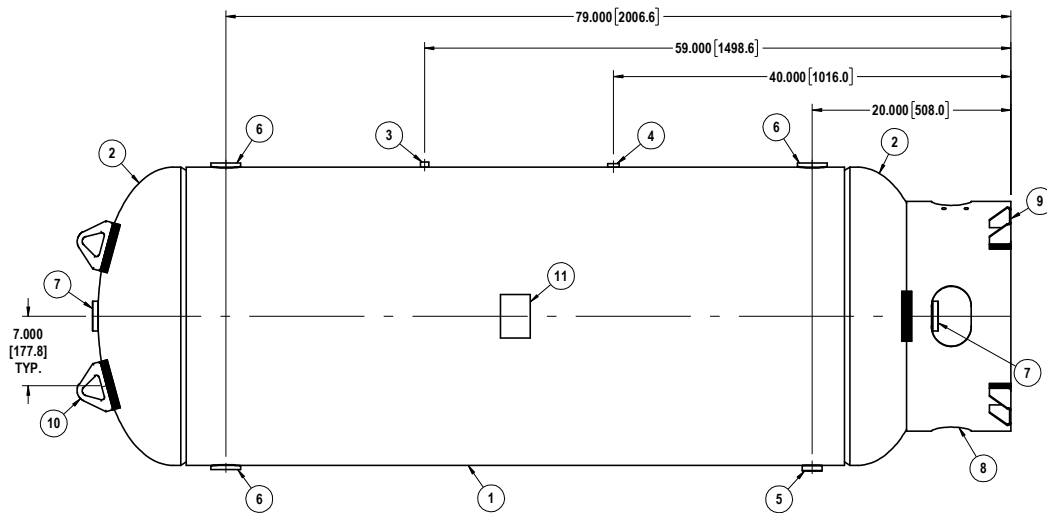
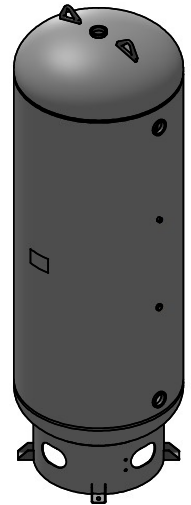
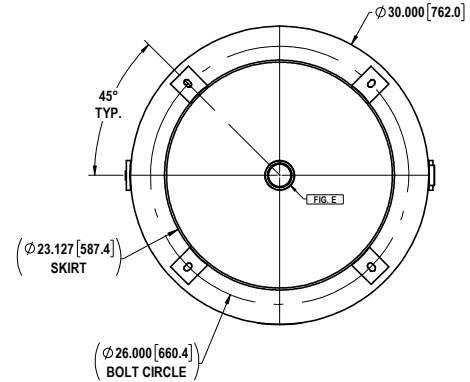
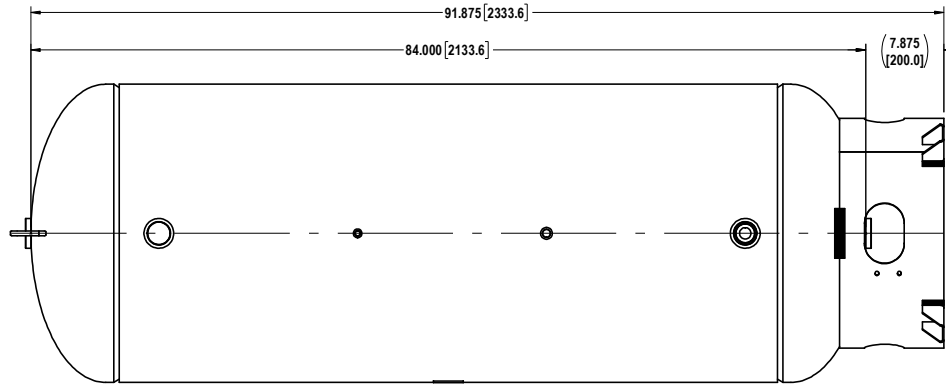

ITEM#	DESCRIPTION	QTY.
11	NAME PLATE	1
10	LIFTING LUG	2
9	OPTIONAL SKIRT SUPPORT	4
9	OPTIONAL SKIRT SUPPORT	4
8	OPTIONAL SKIRT	1
8	SKIRT	1
7	2" NPT COUPLING	2
6	2" NPT COUPLING	3
5	1" NPT COUPLING	1
4	1/2" NPT COUPLING	1
3	1/4" NPT COUPLING	1
2	HEAD	2
1	SHELL	1

NOT FOR PRODUCTION USE

MORGANTON 240 GALLON VERT. VESSEL -ASME- SEC. VIII DIV. 1	TOLERANCES, IF NOT INDICATED, ACCORDING TO: C-G SE 03.03 / 3
	DWG. NO. VES0009907
	REV. 0