

THIS DRAWING & SPECIFICATIONS ARE PROPERTY OF MORGANTON PRESSURE VESSELS AND MAY NOT BE COPIED, REPRODUCED, OR USED IN WHOLE OR PART, AS A BASIS FOR DESIGN, MANUFACTURE, OR SALE WITHOUT PRIOR PERMISSION FROM MORGANTON PRESSURE VESSELS.

DESIGN INFORMATION	
SPECIFICATION	VALUE
DIAMETER (O.D.)	36.000"
MAWP	165 PSI AT 650°F
MDMT	-20°F AT 165 PSI
CAPACITY	APPROX 500 GALLONS
APPROX. WEIGHT	850 LBS

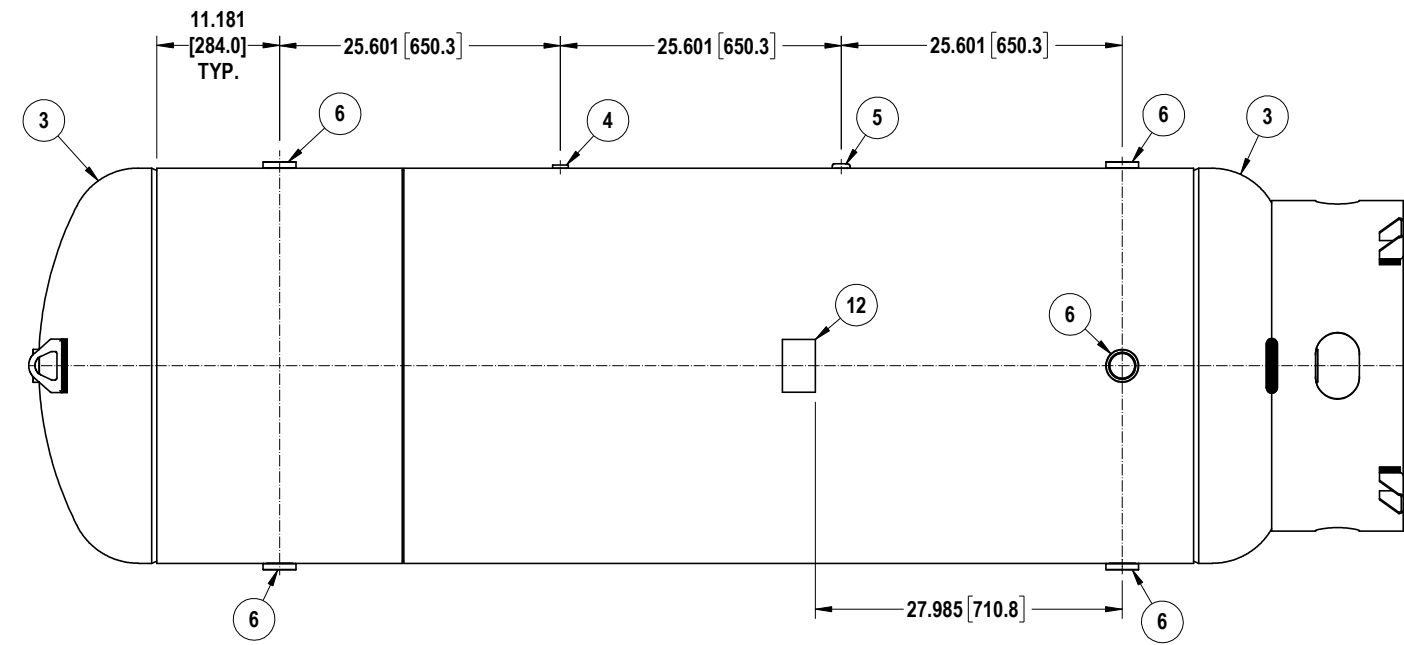
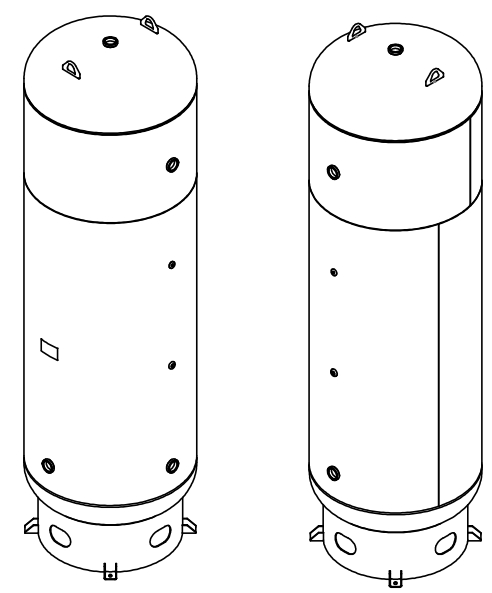
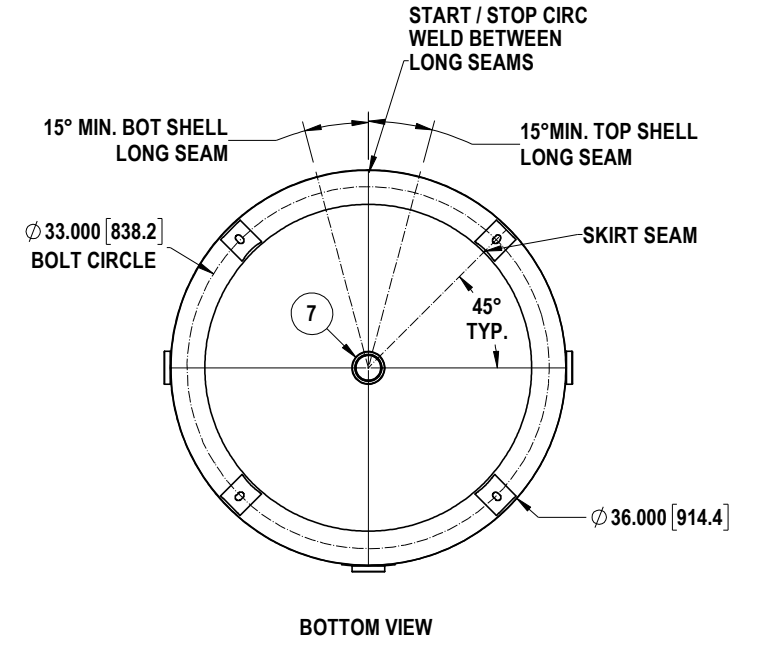
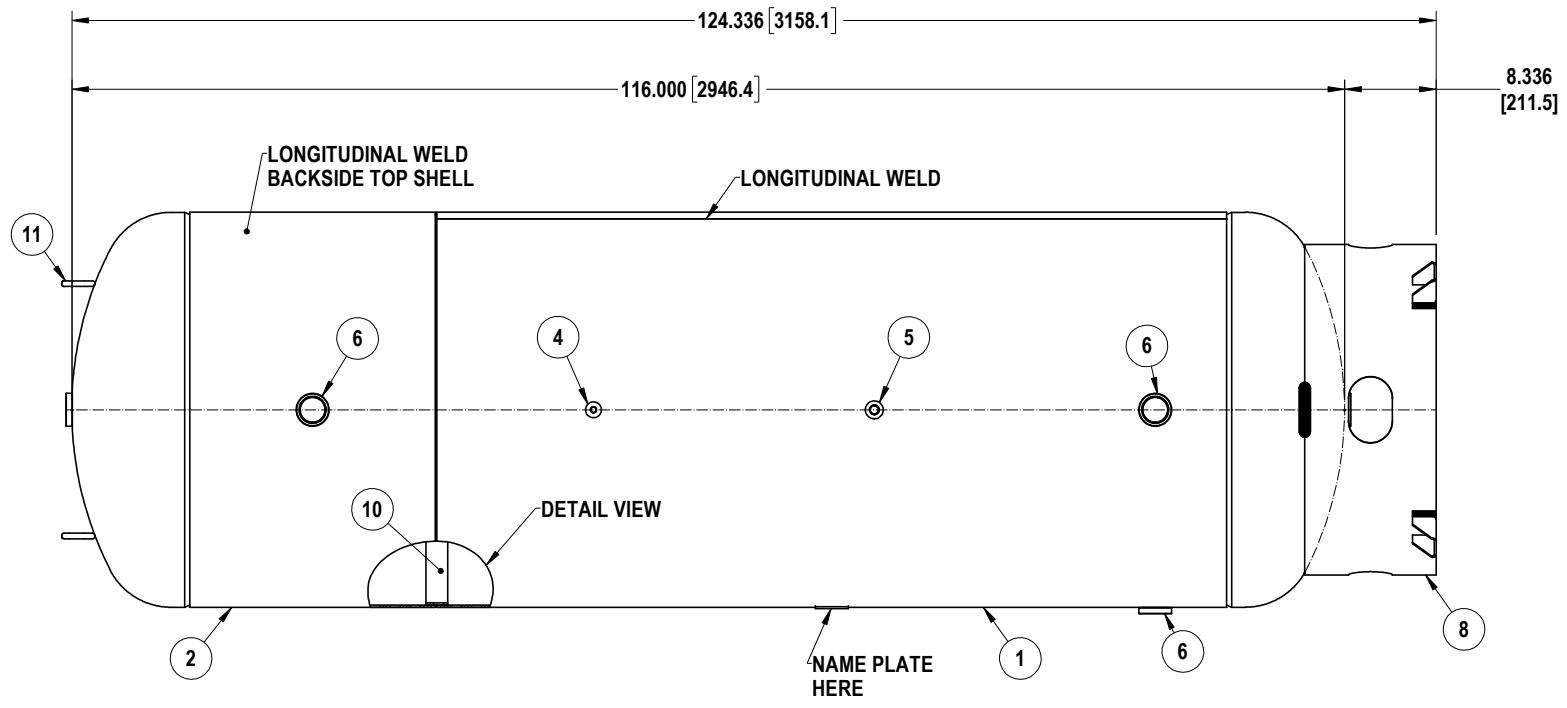
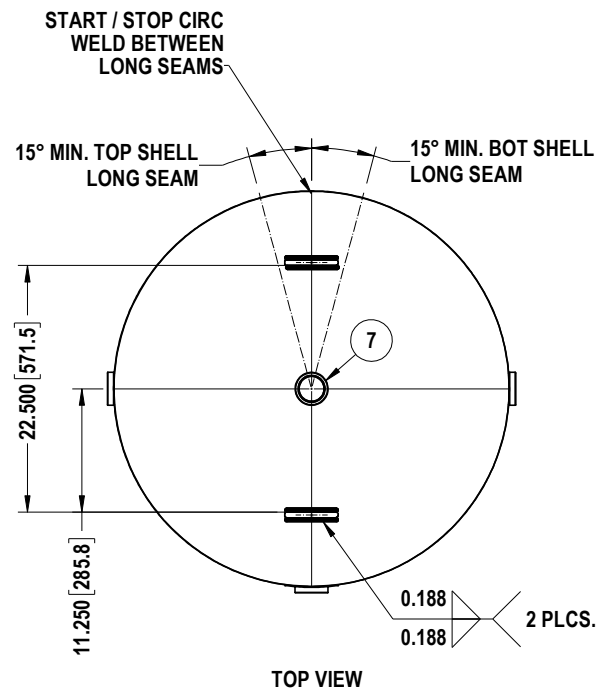

ITEM#	DESCRIPTION	QTY.
12	NAME PLATE	1
11	LIFTING LUG	2
10	BACKING STRIP	1
9	SKIRT SUPPORT	4
8	36" SKIRT	1
7	2" NPT COUPLING	2
6	2" NPT COUPLING - PROFILED	5
5	1/2" NPT FLAT COUPLING	1
4	1/4" NPT FLAT COUPLING	1
3	HEAD	2
2	TOP SHELL	1
1	BOTTOM SHELL	1

**MORGANTON** TOLERANCES, IF NOT INDICATED, ACCORDING TO:  
C-G SE 03.03 / 3

-ASME- SECTION VIII DIV. 1  
500 GALLON  
VERTICAL AIR RECEIVER

DWG. NO. **VES0010667**

NOT FOR PRODUCTION USE