

THIS DRAWING & SPECIFICATIONS ARE PROPERTY OF MORGANTON PRESSURE VESSELS AND MAY NOT BE COPIED, REPRODUCED, OR USED IN WHOLE OR PART, AS A BASIS FOR DESIGN MANUFACTURE OR SALE WITHOUT PRIOR PERMISSION FROM MORGANTON PRESSURE VESSELS.

DESIGN INFORMATION	
SPECIFICATION	VALUE
DIAMETER (O.D.)	30.000"
MAWP	200 PSI AT 650°F
MDMT	-20°F AT 200 PSI
CAPACITY	APPROX 240 GALLONS
APPROX. WEIGHT	735 LBS

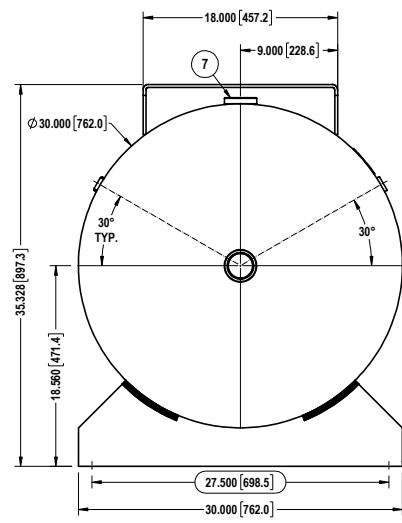
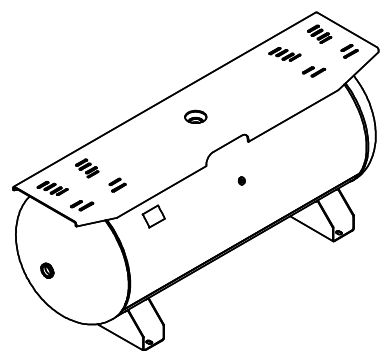
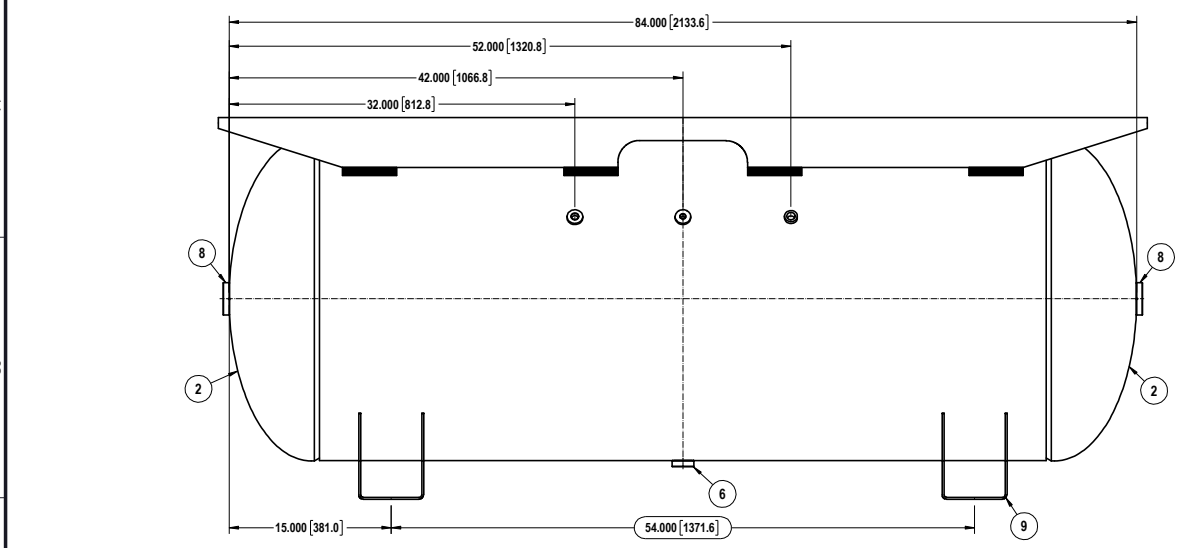
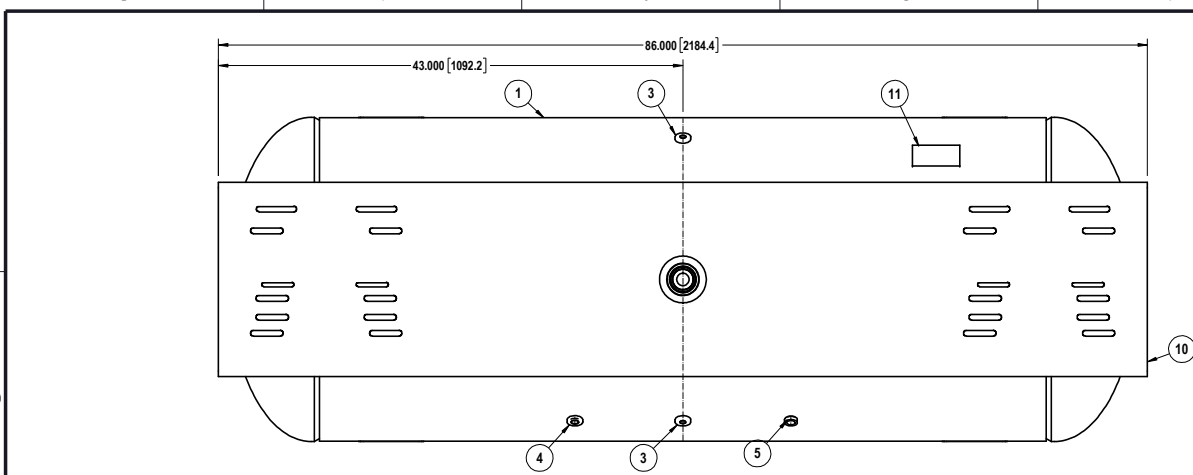

ITEM#	DESCRIPTION	QTY.
11	NAME PLATE	1
10	TOP PLATE	1
9	LEG	2
8	2" NPT COUPLING	2
7	2" NPT COUPLING	1
6	1" NPT COUPLING	1
5	1/2" NPT COUPLING	1
4	3/8" NPT FLAT COUPLING	1
3	1/4" NPT FLAT COUPLING	2
2	HEAD	2
1	SHELL	1

NOT FOR PRODUCTION USE

**MORGANTON**  
 240 GALLON  
 HORIZONTAL VESSEL  
 -ASME-  
 SEC. VIII DIV. 1

TOLERANCES, IF NOT INDICATED, ACCORDING TO:  
 C-G SE 03.03 / 3  
 DWG. NO. VES09207

8 7 6 5 4 3 2 1